

2-way flow control valves are flow valves (throttle valves) with integrated pressure balance. The valves control an adjustable volume flow independently of pressure modification in the inlet or outlet line automatically to obtain a constant value. They can be mounted on the inlet or outlet side of the consumer. Due to the screen – like design of the adjusting throttle, the value is largely independent of the fluid viscosity.

FEATURES

- Mounting surface according to Schiedrum internal standard
- Assembly on connection plates with pipe joints or control block
- 2 setting volume flow ranges
- scaled control knob, setting angle 150°
- control knob can be locked optionally - VW locking E 10
- with by-pass check valve
- standard sealing material Buna N / NBR, other materials are possible
- for volume flow control in both flow directions, volume flow rectifier boards type 71 can be delivered

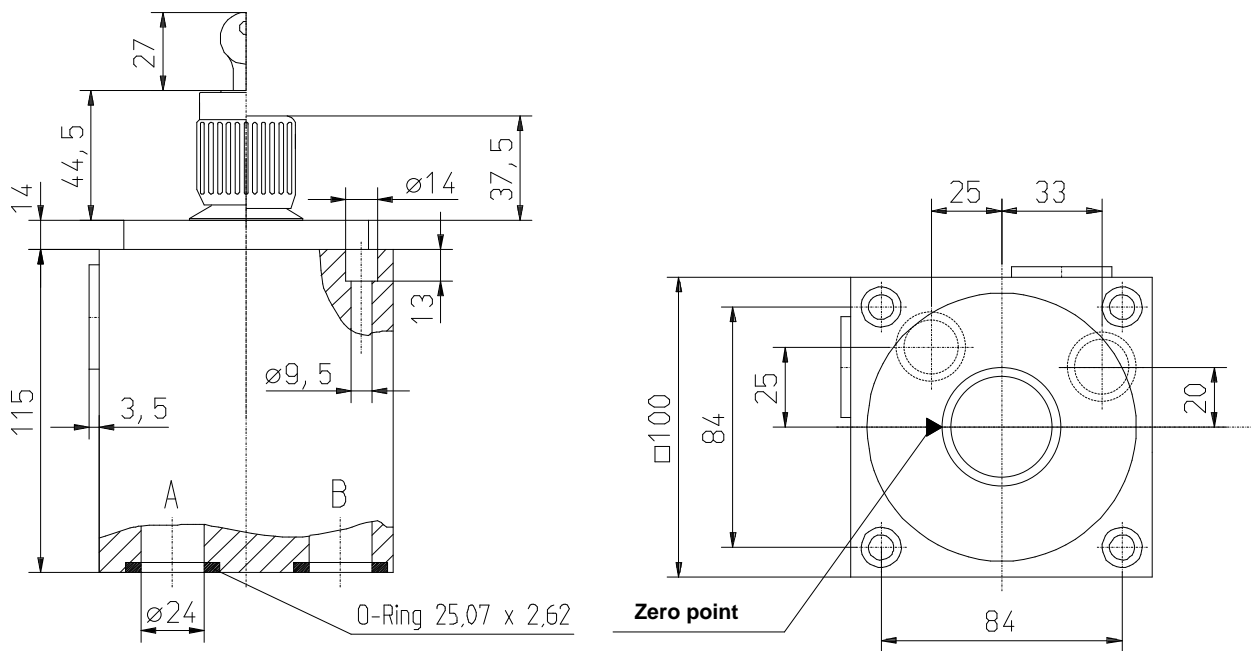

ORDER INFORMATION

The scope includes the o-rings for sealing the connecting holes, two screws M8 x 110 DIN 912 -10.9 M_A 30 Nm and in the case "S" one safety key.

Name — **2-Way flow control valve 201 D R S 160 M15**

Types series

Series code letter

Standard attached

By-pass check valve

Actuation: control knob without lock = **without Code**

control knob with lock = **S**

rated volume flow: in l/min 100, 160

Supplementary data for special models

e.g. special Viton sealings (FKM) = **M 15**

without bypass check valve = **M40**

ACCESSORY

Connecting plates
Flow rectifier plates

see dimension sheet 9-74-201-0003
 see dimension sheet 71D-8

CHARACTERISTICS

1. General

Symbol

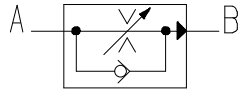

Design

setting throttle: rotary disk valve with radial slit, orifice-type
 Differential pressure valve (pressure balance): switched in series with the adjustment throttle
 Check valve: spring loaded ball seated valve

Weight

approx. 7 kg

Mounting position

any

Direction of volume flow

A to B controlled, B to A unthrottled return flow

Ambient temperature range

25°C to +80°C

2. Hydraulic characteristics

Rated pressure / max. pressure

210 bar for all connections

Hydraulic fluid

Hydraulic oil according to DIN 51 524 (1,2)

Hydraulic fluid temperature range

-20°C up to +70 °C

Viscosity range

5 – 350 mm²/min

Rated volume flow

100 – 160 L/min

min. adjustable volume flow

200 cm³/min

max. permitted volume flow via check valve

200 L/min

Contamination level/filtering

General permit table class 18/15 according to ISO 4406 or 9 according to NAS 1638 (recommended filter: min. retaining rate $\beta_{10-15} \geq 75$)

3. Type of actuation

manual via control knob

Setting angle

150°

Controlling torque

approx. 150 Ncm

CHARACTERISTICS

Q-S characteristics; Q=f (scale mark)

Fig. 1 shows a typical dependency of the volume flow as a function of the control knob scaling (the scale is linear).

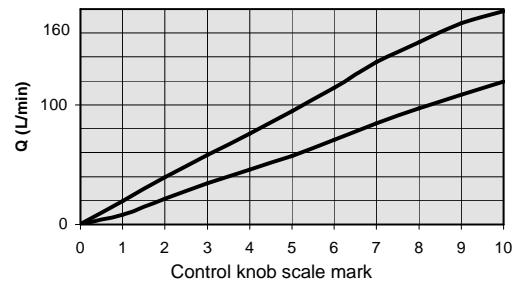

Q-Δp characteristics; Q=f (Δp)

Fig. 2 shows the control behaviour of the valve for the volume flow direction A to B for the various rated flow volume ranges as well as the minimum pressure difference required for the function.

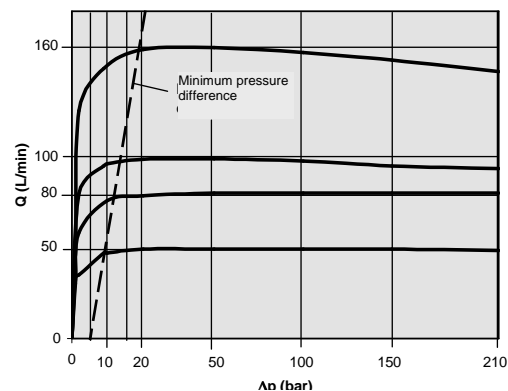

Δp-Q characteristics; Δp=f (Q)

Fig. 3 shows the pressure loss of the valve for the volume flow direction B to A through the by-pass return with the setting screen closed.

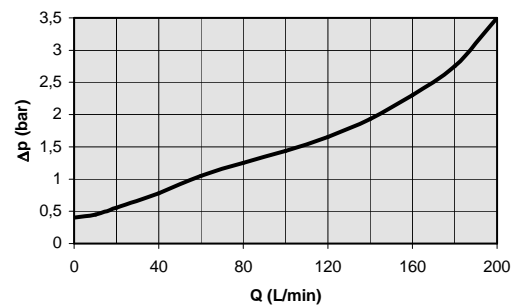

Description of the Valve

1. The valve

The valves automatically control an adjustable recharging flow constant within the function limits independently of pressure variations in this supply or discharge line. A minimum pressure difference between supplying discharged side of the valve must be present. They may be integrated at the supply or discharge side of the consumer. The volume flow can be controlled infinitely by means of the control knob with a scale graduation from zero till ten. The set pressure range is from zero to the selected rated volume flow. For a wide range of application, the setting orifice for controlling the volume flow is not affected by viscosity or contamination. This is achieved by setting throttle with orifice-like design developed by us.

A volume flow is made independent of the pressure by means of the differential pressure valve (pressure balance). It provides a constant pressure difference at the setting orifice and is arranged downstream of the orifice (secondary control).

Due to the very compact design, the flow can be adjusted within msec. in case of pressure changes. The pressure balance is open in its normal position. The volume flow is controlled in one direction of flow only. The direction of the control flow is indicated by the symbol on the name plate. In opposite direction of flow, there is a bypass check valve for an unthrottled return flow at a very small pressure loss. It is designed as a spring-loaded ball-seated valve.

2. Materials

The valve parts are made of engineering steel. The valve housing is bronzed, the top is galvanized and all wear parts are hardened. The unlockable control knob is made from aluminium and plastic.

For applications in excess of the given specification, please contact Schiedrum.

All specified parameters are partially based on long user's experience and partly on measurements made in laboratories. The data are typical of the valve and can deviate in series. All measurements were carried out on a test stand with an oil viscosity of 36mm²/sec and a filter mesh of < 10 µm. All data given here should be used as description of the product only and they are not to understand as warranty in the sense of law.