

2-way flow control valves are flow valves (throttle valves) with integrated pressure balance. The valves control an adjustable volume flow independently of pressure modification in the inlet or outlet line automatically to obtain a constant value. This type of valve is made for mounting in a front plate. They can be mounted on the inlet or outlet side of the consumer. Due to the screen – like design of the adjusting throttle, the value is largely independent of the fluid viscosity.

FEATURES

- Direct connection via pipe thread
- front panel installation
- 13 setting volume flow ranges
- scaled control knob
- control knob can be locked optionally - VW locking E 10
- with by-pass check valve
- standard sealing material Buna N / NBR, other materials are possible
- for volume flow control in both flow directions, volume flow rectifier boards type 71 can be delivered

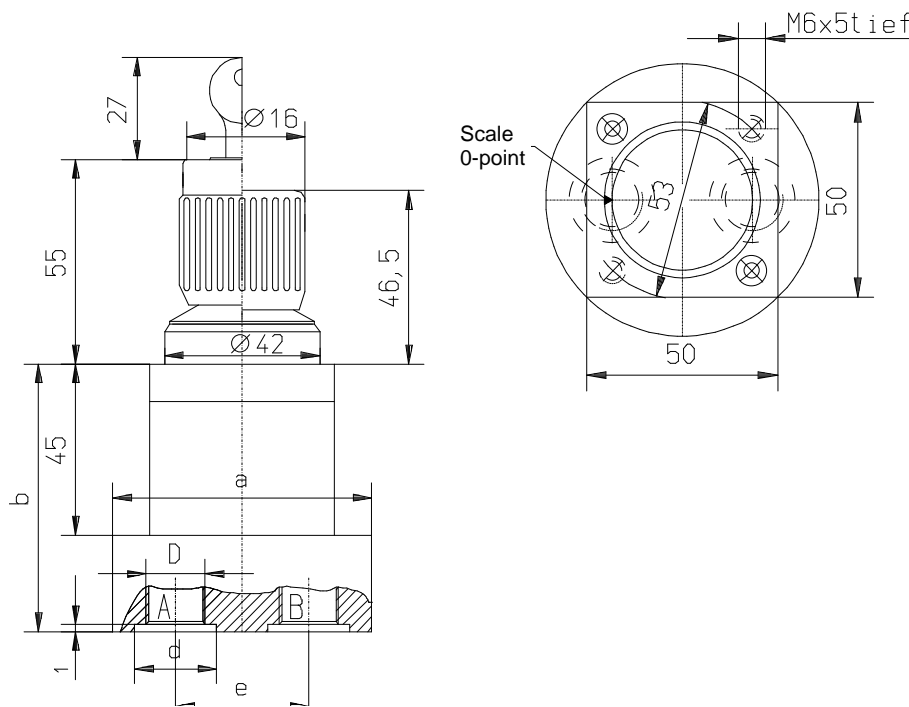

ORDER INFORMATION

In the case of design „S“ one safety key.

Name — **2-Way flow control valve 22 E R S 10 H 2 M15**

Types series

Series code letter

Standard attached

By-pass check valve

Actuation: control knob without lock = **without Code**

Control knob with lock = **S**

Rated volume flow: in cm³/min **63; 100; 160; 250; 400; 630**
 in L/min **1; 1.6; 2.5; 4.0; 6.3; 10; 16**

pressure stage: N = up to 100 bar; H = up to 210 bar

connection size: 2 = G ¼; 3 = G³/₈; 4 = G ½

Supplementary data for special models

e.g. special Viton sealings (FKM) = **M 15**

without bypass check valve = **M40**

ACCESSORY

Flow rectifier plates:

see dimension sheet 71 BZ – 9-74-071-0017

CHARACTERISTICS

1. General

Symbol

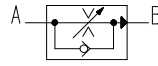

Design

setting throttle: rotary disk valve with radial slit, orifice-type
Differential pressure valve (pressure balance): switched in series with the adjustment throttle

Check valve: spring loaded ball seated valve
any

Mounting position

Direction of volume flow

Weight

Ambient temperature

A to B controlled, B to A unthrottled return flow

approx. 1.4 kg

-25°C to +80°C

2. Hydraulic Characteristic

Rated pressure

Hydraulic fluid

Hydraulic fluid temperature range

Range of viscosity

Rated volume flow

pressure stage N = 100 bar; H = 210 bar

Hydraulic oil according to DIN 51 524 (1,2)

-20°C to +70°C

5 – 350 mm²/min

63 – 100 – 160 – 250 – 400 – 630 cm³/min

1.0 – 1.6 – 2.5 – 4.0 – 6.3 – 10 – 16 L/min

min. controllable volume flow

10 cm³/min

max. permitted Volume flow via check valve

30 l/min

Contamination level

class 18/15 according to ISO 4406 or 9 according to NAS 1638

3. Type of actuation

Setting angle

Controlling torque

manual via control knob

150°

approx. 100 Ncm

CHARACTERISTIC

Q-S characteristic; $Q = f(\text{scale mark})$

Fig. 1 shows a typical dependency of the volume flow as a function of the control knob scaling (the scale is linear).

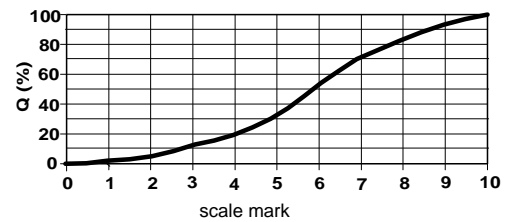

Q- Δp characteristic; $Q = f(\Delta p)$

Fig. 2 shows the control behaviour of the valve for the volume flow direction A to B for the various rated flow volume ranges as well as the minimum pressure difference required for the function.

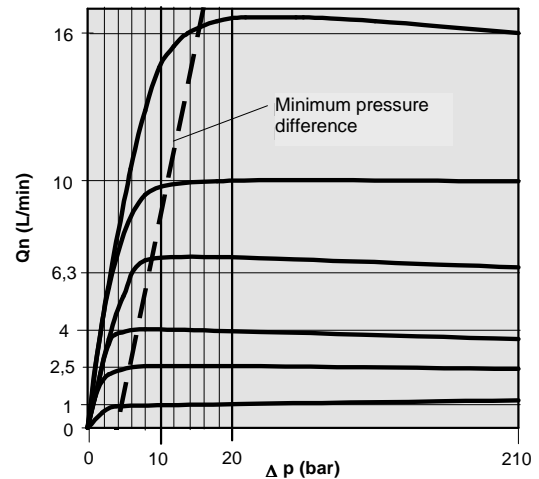

Δp-Q characteristic; $\Delta p = f(Q)$

Fig. 3 shows the pressure loss of the valve for the volume flow direction B to A.

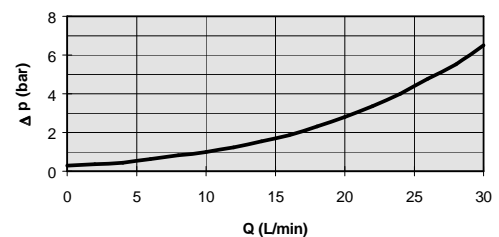

Temperature influence

Fig. 4 shows the variation in flow rate Δp in relation to the oil temperature for 4 different oil viscosity's. In this case, Δp is the increase in flow rate as a percentage of the pre-set flow rate with an oil temperature of 20°C. The sensitivity to temperature cannot be perceived for moderate and heavy flow rates. Thin oils give the lowest variation in flow rate for low flow rates and great variation in temperature.

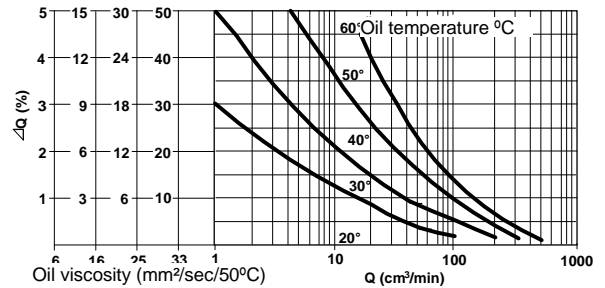

Description of the valve

1. The valve

The valves automatically control an adjustable recharging flow constant within the function limits independently of pressure variations in this supply or discharge line. A minimum pressure difference between supplying discharged side of the valve must be present. They may be integrated at the supply or discharge side of the consumer. The volume flow can be controlled infinitely by means of the control knob with a scale graduation from zero till ten. The set pressure range is from zero to the selected rated volume flow. For a wide range of application, the setting orifice for controlling the volume flow is not affected by viscosity or contamination. This is achieved by setting throttle with orifice-like design developed by us.

A volume flow is made independent of the pressure by means of the differential pressure valve (pressure balance). It provides a constant pressure difference at the setting orifice and is arranged downstream of the orifice (secondary control).

Due to the very compact design, the flow can be adjusted within msec. in case of pressure changes. The pressure balance is open in its normal position. The volume flow is controlled in one direction of flow only. The direction of the control flow is indicated by the symbol on the name plate. In opposite direction of flow, there is a bypass check valve for an unthrottled return flow at a very small pressure loss. It is designed as a spring-loaded ball-seated valve.

2. Materials

The valve parts are made of engineering steel. The valve housing is bronzed, the top is galvanized and all wear parts are hardened. The unlockable control knob is made from aluminium and plastic.

For applications in excess of the given specification, please contact Schiedrum.

All specified parameters are partially based on long user's experience and partly on measurements made in laboratories. The data are typical of the valve and can deviate in series. All measurements were carried out on a test stand with an oil viscosity of 36mm²/sec and a filter mesh of < 10 µm. All data given here should be used as description of the product only and they are not to understand as warranty in the sense of law.